

KKI 7164-91 TI

EN Instruction manual

Your hob combines exceptional ease of use with excellent effectiveness. Once you have read the instructions, operating your hob will not be a problem.

Before being packed and leaving the factory, the safety and functions of this hob were carefully tested.

We ask you to read the User Manual carefully before switching on the appliance. Following the directions in this manual will protect you from any misuse.

Keep this User Manual and store it near at hand.

The instructions should be followed carefully to avoid any unfortunate accidents.

Important!

The appliance may only be operated when you have read and understood this manual thoroughly.

The appliance is designed solely for cooking. Any other use (eg heating a room) is incompatible with the appliance's intended purpose and can pose a risk to the user.

The manufacturer reserves the right to introduce changes which do not affect the operation of the appliance.

CONTENTS

Basic Information.....	2
Safety instructions.....	4
Description of the appliance.....	9
Installation.....	10
Operation.....	15
Cleaning and maintenance.....	28
Troubleshooting.....	30
Specification.....	32

SAFETY INSTRUCTIONS

Warning: The appliance and its accessible parts become hot during use. Care should be taken to avoid touching heating elements. Children less than 8 years of age shall be kept away unless continuously supervised.

This appliance can be used by children aged from 8 years and above and persons with reduced physical, sensory or mental capabilities or lack of experience and knowledge if they have been given supervision or instruction concerning use of the appliance in a safe way and understand the hazards involved. Children shall not play with the appliance. Cleaning and user maintenance shall not be made by children without supervision.

Warning: Unattended cooking on a hob with fat or oil can be dangerous and may result in fire.

NEVER try to extinguish a fire with water, but switch off the appliance and then cover flame e.g. with a lid or a fire blanket.

Warning: Danger of fire: do not store items on the cooking surfaces.

SAFETY INSTRUCTIONS

Warning: If the surface is cracked, switch off the appliance to avoid the possibility of electric shock.

Metallic objects, such as knives, forks, spoons and lids should not be placed on the hob surface since they can get hot.

After use, switch off the hob element by its control and do not rely on the pan detector.

The appliance is not intended to be operated by means of an external timer or separate remote-control system.

You should not use steam cleaning devices to clean the appliance.

SAFETY INSTRUCTIONS FOR USE

- Before using the induction hob for the first time, carefully read its user manual. This will ensure user safety and prevent damage to the appliance.
- If the induction hob is operated in immediate vicinity to the radio, television set or other radio-frequency-emitting device, make sure that the hob's touch sensor controls operate correctly.
- The hob must be connected by a qualified installer.
- Do not install the appliance near a refrigerator.
- Furniture, where the hob is installed must be resistant to temperatures up to 100°C. This applies to veneers, edges, surfaces made of plastics, adhesives and paints.
- The appliance may only be used once fitted in kitchen furniture. This will protect the user against accidental touching the live part.
- Repairs to electrical appliances may only be conducted by specialists. Improper repairs can be dangerous to the user.
- The appliance is not connected to mains when it is unplugged or the main circuit breaker is switched off.
- Plug of the power cord should be accessible after appliance has been installed.
- Ensure that children do not play with the appliance.
- This appliance is not intended for use by persons (including children) with physical, mental or sensory handicaps, or by those who are inexperienced or unfamiliar with the appliance, unless under supervision or in accordance with the instructions as communicated to them by persons responsible for their safety.
- **Persons with implanted devices, which support vital functions (eg, pacemaker, insulin pump, or hearing aids) must ensure that these devices are not affected by the induction hob (the frequency of the induction hob is 20-50 kHz).**
- Once power is disconnected all settings and indications are erased. When electric power is restored caution is advisable. If the cooking zones are hot, „H“ residual heat indicator will be displayed. Also child lock key will be displayed, as when the appliance is connected for the first time.
- Built-in residual heat indicator can be used to determine if the appliance is on and if it is still hot.
- If the mains socket is near the cooking zone, make sure the cord does not touch any hot areas.
- When cooking using oil and fat do not leave the appliance unattended, as there is a fire hazard.
- Do not use plastic containers and aluminium foil. They melt at high temperatures and may damage the cooking surface.
- Solid or liquid sugar, citric acid, salt or plastic must not be allowed to spill on the hot cooking zone.
- If sugar or plastic accidentally fall on the hot cooking zone, do not turn off the hob and scrape the sugar or plastic off with a sharp scraper. Protect hands from burns and injuries.

SAFETY INSTRUCTIONS FOR USE

- When cooking on induction hob only use pots and pans with a flat base having no sharp edges or burrs as these can permanently scratch the cooking surface.
- Induction hob cooking surface is resistant to thermal shock. It is not sensitive to cold nor hot.
- Avoid dropping objects on the cooking surface. In some circumstances, point impacts such as dropping a bottle of spices, may lead to cracks and chipping of the cooking surface.
- If any damage occurs, seething food can get into the live parts of the induction hob through damaged areas.
- If the cooking surface is cracked, switch off power to avoid the risk of electric shock.
- Do not use the cooking surface as a cutting board or work table.
- Do not place metal objects such as knives, forks, spoons, lids and aluminium foil on the cooking surface as they could become hot.
- Do not install the hob over a heater without a fan, over a dishwasher, refrigerator, freezer or washing machine.
- If the hob has been built in the kitchen worktop, metal objects located in a cabinet below can be heated to high temperatures through the air flowing from the hob ventilation system. As a result it is recommended to use a partition (see Figure 2).
- Please follow the instructions for care and cleaning of induction hob. In the event of misuse or mishandling warranty may be void.

HOW TO SAVE ELECTRICITY



Using the electricity in a responsible manner not only saves money, but also helps protect the environment. So let's save electricity! This is how it's done:

- **Use the correct cookware.**

Cookware with flat and a thick base can save up to 1/3 of electricity. Please remember to cover cookware with the lid, otherwise electricity consumption increased four times!

- **Always keep the cooking zones and cookware bases clean.**

Dirt prevents proper heat transfer. Often burnt stains can be removed only with agents harmful to the environment.

- **Avoiding unnecessary lifting the lid to peek into the pot.**

- **Do not install the hob in the immediate vicinity of refrigerator / freezer.**

The electricity consumption is then unnecessarily increased.

UNPACKING



The appliance was protected from damage at the time of transport. After unpacking, please dispose of all elements of packaging in a way that will not cause damage to the environment. All materials used for packaging the appliance are environmentally friendly; they are 100% recyclable and are marked with the appropriate symbol.

Important! Keep the packaging material (bags, Styrofoam pieces, etc.) out of reach of children during unpacking.

DISPOSAL

In accordance with European Directive **2012/19/UE** and Polish legislation regarding used electrical and electronic goods, this appliance is marked with the symbol of the crossed-out waste container.



This marking means that the appliance must not be disposed of together with other household waste after it has been used. The user is obliged to hand it over to waste collection centre collecting used electrical and electronic goods. The collectors, including local collection points, shops and local authority departments provide recycling schemes. Proper handling of used electrical and electronic goods helps avoid environmental and health hazards resulting from the presence of dangerous components and the inappropriate storage and processing of such goods.

DESCRIPTION OF THE APPLIANCE

Description of hob

Induction cooking zone

booster Ø 180 mm (rear right)

Induction cooking zone

booster Ø 160-180 mm
(rear left)

Induction cooking zone

booster Ø 210-220 mm
(front left)

Induction cooking zone

booster Ø 180 mm (front right)

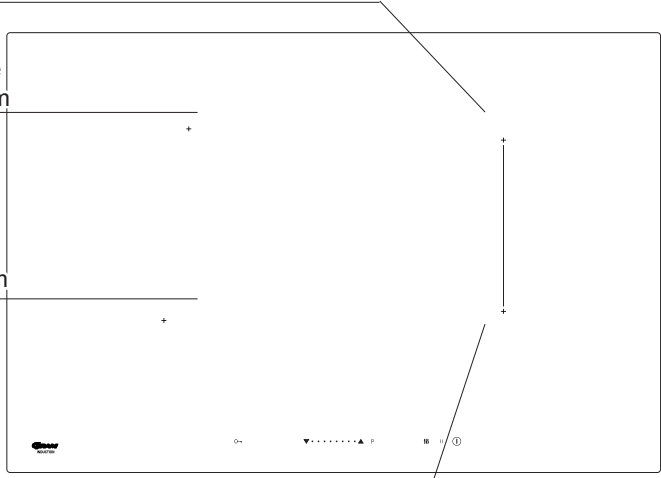

Control Panel

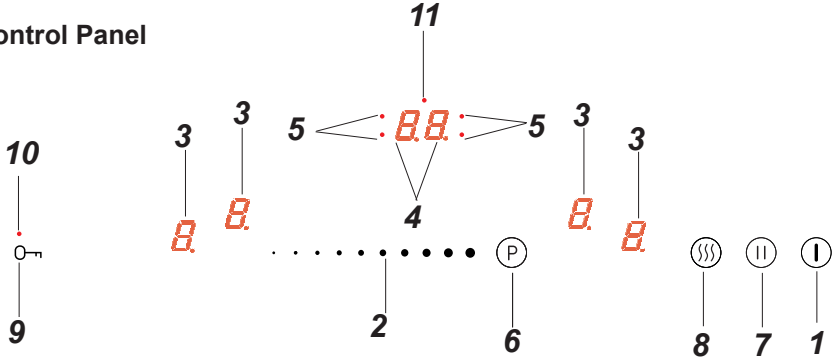

1. On/off sensor field
2. Heat setting selection sensor field
3. Cooking zone indicator
4. Timer display
5. Timer indicator light
6. Booster sensor field
7. Stop'n go function sensor field
8. Keep Warm function sensor field
9. Child lock sensor
10. Child lock indicator light
11. Kitchen timer indicator light

INSTALLATION

▶ Making the worktop recess

- Worktop thickness should be 28 - 40 mm, while its width at least 600 mm. The worktop must be flat and level. Edge of the worktop near the wall must be sealed to prevent ingress of water or other liquids.
- There should be sufficient spacing around the opening, in particular, at least 50 mm distance to the wall and 60 mm distance to the front edge of worktop.
- The distance between the edge of the opening and the side wall of the furniture should be minimum 55 mm.
- Worktop must be made of materials, including veneer and adhesives, resistant to a temperature of 100°C. Otherwise, veneer could come off or surface of the worktop become deformed.
- Edge of the opening should be sealed with suitable materials to prevent ingress of water.
- Worktop opening must cut to dimensions as shown on figure 1.
- Ensure minimum clearance of 25 mm below the hob to allow proper air circulation and prevent overheating. See Figure 2.

①

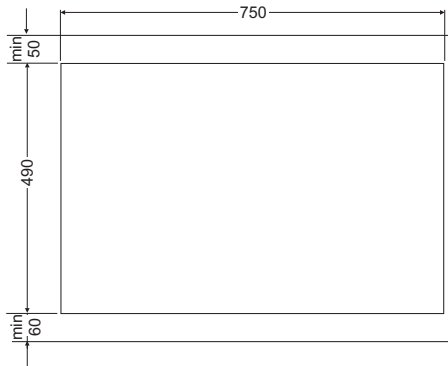

INSTALLATION

Fig.2

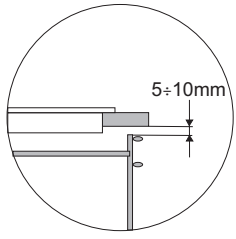
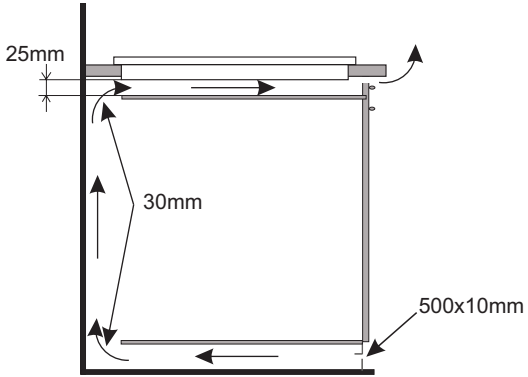

Installing hob in kitchen cabinet worktop.

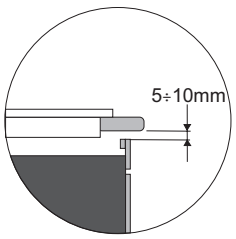
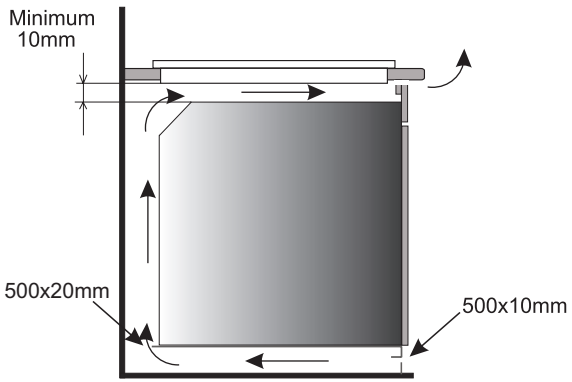

Installing hob in kitchen worktop above oven with ventilation.



Do not install the hob above the oven without ventilation.

INSTALLATION

Installing hob

- Using an electrical cord, connect the hob according to electrical diagram provided.
- Remove dust from the worktop, insert hob into the opening and press in firmly (Figure 3).

Fig. 3

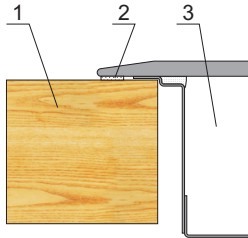

- 1 - Worktop
- 2 - Hob flange gasket
- 3 - Ceramic hob

Assembly of the gasket

Depending on the model, the seal is already installed at the factory (fig.1)

If the seal has not been fitted at the factory, proceed as follows:

Before installing the hob in the cut-out worktop, the gasket is to be attached to the back of the hob (pic. 2)

To do this, first peel off the protective film from the self-adhesive seal and glue the gasket as close as possible to the outer edge of the hob (fig. 3,4).

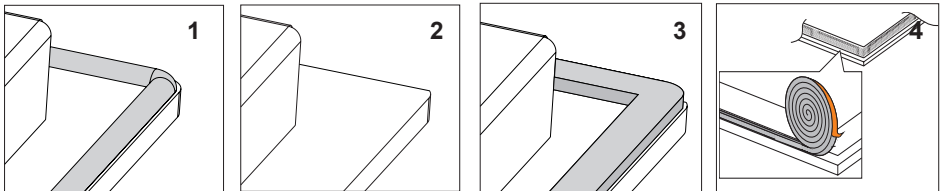

Do not install the appliance without the foam gasket.

Then turn the hob over insert it into the cut-out of the furniture. Align the positioning symmetrically so that the distances between the hob and the countertop is the same on all sides. (fig. 5)

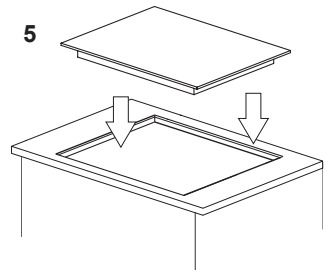

INSTALLATION

▶ Connecting to electrical mains

The hob is designed to be connected to one-phase 230V 1N~ mains power supply. Before connecting the appliance to the mains power supply, the user must ensure that the mains data corresponds to the information given on the manufacturer's data plate, which can be found on either the back or the right-hand side of the hob or the copy of this plate which is enclosed with this guidance.

The hob is equipped with a power supply cable. Before connecting the hob to the power supply, it is important that you read the information given below.

▶ Tips for the installer

The hob is equipped with a terminal block allowing different connections appropriate for a specific type of power supply.

Terminal block allows the following connections:

- single-phase 230 V ~
- two-phase 400 V 2N ~
- three-phase 400 V 3N ~

The hob can be adapted to a specific type of power supply by bridging the appropriate terminals according to wiring diagram. Wiring diagram is placed on the hob's underside. The terminal block can be accessed by removing the lid on hob's underside. Remember to match the power cord to the type of connection and the hob's power rating.

Important!

Remember to connect the neutral lead to correct terminal block clamp, marked with . The electrical system supplying the hob must be protected by a properly selected tripping device or a circuit breaker allowing to disconnect the power supply in an emergency.









Before connecting the appliance to power, please carefully read the information provided on the rating plate and wiring diagram.

Connecting the hob other than shown on the wiring diagram may damage the hob.

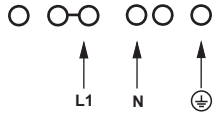
CAUTION! The installer is obliged to provide the user with "appliance electrical connection certificate" (enclosed with the warranty card). After installation, the installer should also provide information on the connection made:

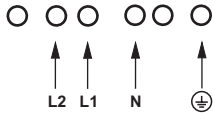
- single-phase, two-phase or three-phase,
- conductor cross-section,
- electrical protection (fuse type).

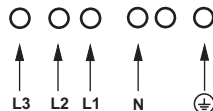
INSTALLATION

WIRING DIAGRAM Important! Heating elements operate at 230V.					
Important! For each connection the protective conductor must be connected to the terminal marked  .			Type / Conductor cross section	Fuse protection	
1	For a 230 V single phase connection with a neutral lead, terminals L1, L2 are bridged, neutral lead is connected to terminal N, and the protective conductor to  .	1N~		HO5VV-FG 3X 4 mm ²	min.30 A
2*	For a 230/400 V two phase connection with a neutral lead, neutral lead is connected to terminal N, and the protective conductor to  .	2N~		HO5VV-FG 4X2,5mm ²	min.16 A
3*	For a 230/400 V three phase connection with a neutral lead, neutral lead is connected to terminal N, and the protective conductor to  .	3N~		HO5VV-FG 5X1,5mm ²	min.16 A
L1=R, L2=S, L3=T; N = neutral lead connection;  = protective lead terminal					

* For domestic 3-phase 230/400 V electrical system, connect the remaining wire to the terminal:L3, which is not connected to the hob internal electrical system.

* NN terminals are internally connected, they need not be bridged

OPERATION

▶ Before using the appliance for the first time

- thoroughly clean your induction hob first. The induction hob should be treated with the same care as a glass surface.
- switch on the ventilation in the room or open a window, as the appliance could emit an unpleasant smell during first use.
- operate the appliance while observing all safety guidelines.

▶ Induction cooking zone operation principle

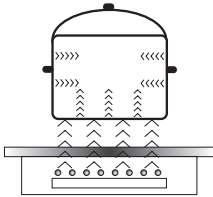

Electric oscillator powers a coil placed inside the appliance. This coil produces a magnetic field, which induces eddy currents in the cookware. These eddy currents induced by the magnetic field cause the cookware to heat up.

This requires the use of pots and pans whose base is ferromagnetic, in other words susceptible to magnetic fields.

Overall, induction technology is characterized by two advantages:

- the heat is only emitted by the cookware and its use is maximised,
- there is no thermal inertia, since the cooking starts immediately when the pot is placed on the hob and ends once it is removed.

Certain sounds can be heard during normal use of the induction hob, which do not affect its correct operation.

- Low-frequency humming. This noise arises when the cookware is empty and stops when water is poured or food is placed in the cookware.
- High-frequency whizz. This noise arises in cookware made of multiple layers of different materials at maximum heat setting. The noise intensifies when using two or more cooking zones at maximum heat setting. The noise will stop or reduce when heat setting is reduced.
- Creaking noise. This noise arises in cookware made of multiple layers of different materials. The noise intensity depends on how the food is cooked.
- Buzzing. Buzzing can be heard when electronics cooling fan operates.

The noises that can be heard during the normal appliance operation are the result of the cooling fan operation, cooking method, cookware dimensions, cookware material and the heat setting. These noises are normal and do not indicate a fault.

OPERATION

The protective device:

If the hob has been installed correctly and is used properly, any protective devices are rarely required.

Fan: protects and cools controls and power components. It can operate at two different speeds and is activated automatically. Fan runs until the electronic system has sufficiently cooled down regardless of the appliance or the cooking zones being turned on or off.

Temperature sensor: Temperature of electronic circuits is continuously monitored by a temperature sensor. If temperature is raised beyond a safe level, this protection system will reduce cooking zone heat setting or shut down the cooking zones adjacent to the overheated electronic circuits.

Pan detection: allows the hob to detect pans placed on a cooking zone. Small objects placed on the cooking zone (eg, spoon, knife, ring ...) will not be recognised as pans and the hob will not operate.

Pan detector

Pan detector is installed in induction hobs. Pan detector starts heating automatically when a pan is detected on a cooking zone and stops heating when it is removed. This helps save electricity.

- When a suitable pan is placed on a cooking zone, the display shows the heat setting.
- Induction requires the use of suitable cookware with ferromagnetic base.

If a pan is not placed on a cooking zone or the pan is unsuitable, the  symbol is displayed. The cooking zone will not operate. If a pan is not detected within 90 seconds, the cooking zone will be switched off.

Switch off the cooking zone using the touch control sensor field rather than by removing the pan.

Pan detector does not operate as the on/off sensor.

The induction hob is equipped with electronic touch control sensor fields, which are operated by touching the marked area with a finger.

Each time a sensor field is touched, an acoustic signal can be heard.

When switching the appliance on or off or changing the heat setting, attention should be paid that only one sensor field at a time is touched. When two or more sensor fields are touched at the same time (except timer and child lock), the appliance ignores the control signals and may trigger a fault indication if sensor fields are touched for a long time.

When you finish cooking switch off the cooking zone using touch control sensor fields and do not rely solely on the pan detector.

OPERATION

The high-quality cookware is an essential condition for efficient induction cooking.

Select cookware for induction cooking

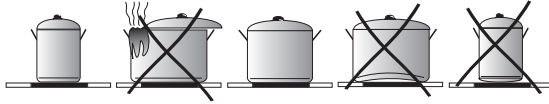

Cookware characteristics.

- Always use high quality cookware, with perfectly flat base. This prevents the formation of local hot spots, where food might stick. Pots and pans with thick steel walls provide superior heat distribution.
- Make sure that cookware base is dry: when filling a pot or when using a pot taken out of the refrigerator make sure its base is completely dry before placing it on the cooking zone. This is to avoid soiling the surface of the hob.
- Lid prevents heat from escaping and thus reduces heating time and lowers energy consumption.
- To determine if cookware is suitable, make sure that its base attracts a magnet.
- **Cookware base has to be flat for optimal temperature control by the induction module.**
- **The concave base or deep embossed logo of the manufacturer interfere with the temperature induction control module and can cause overheating of the pot or pan.**
- **Do not use damaged cookware such as cookware with deformed base due to excessive heat.**
- When you use large ferromagnetic base cookware, whose diameter is less than the total diameter of the cookware, only the ferromagnetic base heats up. This results in a situation where it is not possible to uniformly distribute the heat in the cookware. If the ferromagnetic area is reduced due to inclusion of aluminium parts then the effective heated area can be reduced. Problems with the detection of the cookware could arise or cookware may not be detected at all. To achieve optimum cooking results, the diameter of the ferromagnetic base should match that of the cooking zone. If cookware is not detected in a given cooking zone, it is advisable to try it in a smaller cooking zone.

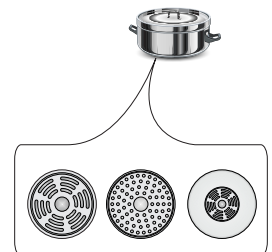

OPERATION

For induction cooking us only ferromagnetic base materials such as:

- enamelled steel
- cast iron
- special stainless steel cookware designed for induction cooking.

Marking of kitchen cookware		Check for marking indicating that the cookware is suitable for induction cooking.
	Use magnetic cookware (enamelled steel, ferrite stainless steel, cast iron). The easiest way to determine if your cookware is suitable is to perform the „magnet test“. Find a generic magnet and check if it sticks to the base of the cookware.	
Stainless Steel	Cookware is not detected	
	With the exception of the ferromagnetic steel cookware	
Aluminium	Cookware is not detected	
Cast iron	High efficiency	
	Caution: cookware can scratch the hob surface	
Enamelled steel	High efficiency	
	Cookware with a flat, thick and smooth base is recommended	
Glass	Cookware is not detected	
Porcelain	Cookware is not detected	
Cookware with copper base	Cookware is not detected	

Cookware size.

- In order to achieve best cooking results, use cookware with bottoms (ferromagnetic part) of the size corresponding to the size of the cooking zone.
- Using cookware with the bottom diameter smaller than the cooking zone size will reduce the effectiveness of the cooking zone and increase cooking time.
- Cooking zones have a lower pot detection limit that depends on the diameter of ferromagnetic part of the pot bottom and the pot material. The use of an unsuitable pot might lead to pot being undetected by a cooking zone.

OPERATION



Control Panel

- Immediately after the appliance is connected to electrical mains, all displays will light up briefly. Your induction hob is then ready for use.
- The induction hob is equipped with electronic touch control sensor fields, which are operated by touching with a finger for at least 1 second.
- Touching of a sensor is accompanied by an acoustic signal to acknowledge.

 No objects should be placed on the sensor fields (this could cause an error). Touch sensor fields should be always kept clean.



Switch on the appliance





Touch and hold the on/off sensor for at least 1 second . Hob indicates correct operation (active) when "0" is shown on the display .

 If you do not set the desired heat setting of the cooking zone within 10 seconds of activating the hob, the appliance will turn off automatically.

Activate cooking zone and set the heat setting.

- Turn on the hob with the  sensor.
- Place the cookware on the desired cooking zone.
- The cookware will be automatically detected and the relevant display  will show flashing "0."

 When cookware is detected on more than one cooking zone touch the display  of the cooking zone you want to use. It will flash.



- To select the desired heat setting slide your finger across the  sensor starting from the left (the display will show the selected heat setting).
- The cooking zone operates.

 A cooking zone is active when its display shows a digit or a letter. This indicates the cooking zone is ready for the heat setting to be set or changed.

OPERATION

Deactivate cooking zones

Deactivate cooking zone by doing one of the following:

- Turn off the hob with the  sensor.
- Touch and hold the  sensor for 3 seconds
- Touch  to activate the cooking zone and slide to the left to reduce the heat setting "0."

Turn off the appliance



The appliance operates when at least one cooking zone is on.

- Turn off the hob with the  sensor.



If a cooking zone is still hot, the relevant display will show the letter "H" or "h" to indicate residual heat. For description of the symbol, see below.

Booster function "P"





Booster function increases the power of the Ø 180 - from 1600W to 2500W

Ø 210-220 - from 2000W to 3000W

Ø 160-180 - from 1200W to 1400W

Bridge from 3200W to 5000W. Place the cookware on the desired cooking zone.

- The cookware will be automatically detected and the relevant display  will show flashing "0."
- Touch  to activate the Booster function — the display will show the letter "P".



Turn off the Booster function:

- Touch the  sensor and slide your finger to "0" to turn off the Booster function.

Booster function can be activated for up to 10 minutes. After that time, the cooking zone heat setting is set to the nominal power (for example, if the heat setting range is 0-9, the nominal power is 9, if the range is 0-12, the nominal power is 12, etc.).

This function can also switch back to the nominal power, if any hob components overheat.

You can reactivate the Booster function when the internal components cool down to safe range. This function will not start automatically.



When you take the pot off the cooking zone when the Booster function is on, a 10-minute countdown will not be interrupted.

OPERATION



Booster function can be activated on two cooking zones at the same time, i.e. on two horizontal or two vertical cooking zones. This function cannot be activated on cooking zones in opposite corners ("crosswise").

The Child Lock function

Child lock function disables all hob controls, for example, to prevent using the appliance by children or for cleaning. The Child Lock function can be set when the appliance is turned on or off. To enable or disable the Child Lock function, hold the  sensor for 5 seconds. When the lock is on, an indicator light next to the  sensor is on.



The hob is locked, even when you turn it on or off with the  sensor. Disconnecting the appliance from electrical mains deactivates the Child Lock.

Residual heat indicator "H"

When you have finished cooking, the induction hob glass within the cooking zone is still hot, this is called residual heat.

If the glass temperature is higher than 60°C*, display of the cooking zone shows "H".



If the glass temperature is 45°C* – 60°C), the cooking zone display shows "h" (low residual heat).



* Temperatures are approximate



When residual heat indicator is on, do not touch the cooking zone as there is a risk of burns and do not place on it any items sensitive to heat!



The "H" or "h" residual heat indicator is not displayed during a power outage. However, cooking zones may still be hot!

OPERATION

Limit the operating time

In order to increase efficiency, the induction hob is fitted with operating time limiter for each of the cooking zones.

The maximum operating time is determined individually depending on the heat setting when cooking. If you only use one heat setting for an extended period of time, the maximum cooking time is given in the table:

Cooking heat setting	Maximum operating time
— = ≡	8h
1	8h
2	8h
3	5h
4	5h
5	5h
6	1.5h
7	1.5h
8	1.5h
9	1.5h
P	10min

After reaching the maximum cooking time, the induction zone deactivates automatically, and the display shows residual heat symbol. The maximum working time applies to a single cooking zone.

Automatic warm-up function

This function initially sets cooking zone heat setting to 9. Activate the function:

To activate the function:

- Place the cookware on the desired cooking zone.
- When cookware is automatically detected select the heat setting 1-8
- Touch the **B** sensor again.

The display will alternately show flashing heat setting and the "A" symbol.

After the warm-up time has elapsed (see table), the cooking zone will automatically switch back to the previously selected heat setting and it will be shown on the display.

If you take the pot off the cooking zone when the warm-up function is active, and then put back on, warm-up function will continue until full warm-up time has elapsed.

Cooking heat setting	The duration of the automatic warm-up function (minutes)
1	48s
2	1min, 12s
3	2min, 18s
4	2min, 30s
5	4min, 24s
6	7min, 12s
7	2 min
8	3min, 12s

OPERATION

Timer



Timer function makes cooking easier by making it possible to set Duration. It can also be used as a Kitchen Timer. You can activate the Timer function only when cooking (when heat setting is greater than "0"). You can use the Timer function on all cooking zones at the same time. Maximum time is 99 minutes (1 minute step).

To set the timer:

- Place the cookware on the desired cooking zone.
- When cookware is auto detected, set the heat setting
- Select the cooking zone for which you want to set the timer.
- To activate the timer touch and hold **8.8.** until you hear a beep. The display will show "00."



You will be setting the second digit first (single minutes), and then the first digit (tens of minutes).

- When you activate the Timer, slide your finger across the . . ● sensor to set the single minutes.
- Touch the timer sensor again to set the tens of minutes.
- Slide your finger across the . . ● sensor to set the tens of minutes.
- If you do not set tens of minutes within 10 seconds, Timer will be set to "0" (for example "06" which means the Timer is set to 6 minutes).

The Timer will start when the indicator light for the selected cooking zone starts flashing (indicator light on the control panel figure 5).

To set the Timer for the next cooking zone, follow the above steps by selecting a different cooking zone. Keep in mind that the Timer function can be set for each cooking zone.



If more than one timer is set the shortest duration is displayed. This is indicated by a flashing indicator light next to the Timer display.

OPERATION

Timer Duration setting can be changed at any time. During cooking, select the cooking zone for which you wish to change timer duration setting, i.e. activate it with the **B** sensor, touch the **B.B**. Timer sensor and change the time setting as per Timer setting instructions.

You can check the remaining cooking time at any time. Touch the **B.B**. Timer sensor; active Timer duration for a selected cooking zone is indicated by a flashing indicator light next to the **B.B**. display.

When the set cooking time has elapsed, you will hear an alarm beep. Touch any sensor to turn it off. The alarm goes off automatically after 2 minutes.

To cancel the Timer touch **B**. (heat setting indicator will be brighter), then touch and hold **B.B** for 3 seconds and touch **B**. to activate the desired cooking zone, then touch **B.B**. and use **• • •** to reduce the time to "00" (see the chapter on how to set the timer for instructions how to set single minutes and tens of minutes).

Kitchen Timer

Timer function can be used as an independent kitchen timer, which does not control any of the cooking zones. To set a kitchen timer, follow all the steps of Timer setting, but do not select any of the cooking zones, i.e. immediately after activating the hob touch the **B.B**. Timer sensor and set the time. Kitchen timer activation will be indicated with a flashing indicator light above the **B.B**. sensor. Cancel the timer in the same way as you cancel the timer for a selected cooking zone.

OPERATION

Stop'n go function (pause II)



Stop'n go function acts like a pause. The Stop'n go function simultaneously suspends operation of all cooking zones and then resumes at the heat settings that were previously set. In order to activate the Stop'n go function, at least one cooking zone must be in use.

Touch the  sensor. All cooking zone displays will show the II symbol. When a cooking zone is hot the II symbol will flash alternately with the letter "H" or "h", depending on cooking zone temperature (residual heat indicator).

To deactivate the Stop'n go function touch the  sensor field again. Cooking zone displays will show the heat setting that was previously set before activation of the Stop'n go function.

Bridge function



The Bridge function allows pairing of two cooking zones into a single combined cooking zone. The Bridge function is very convenient, especially when cooking in large pots such as a baking pan.

The two left or two right cooking zones can be bridged.

To select the Bridge function:

- Turn on the hob.
- Place the baking pan on the left or right cooking zones.
- The pan will be automatically detected and the Bridge function will activate as indicated by the  symbol.



If you do not select heat setting within 10 seconds the Bridge function will be deactivated.

- Select the desired heat setting by sliding your finger across the setting selection sensor field • •

Now both cooking zones can be controlled at the same time.

OPERATION



You can always turn on the Bridge function manually.

In order to activate the Bridge function touch sensor of the cooking zone **B** and then simultaneously touch two sensors of the cooking zones **B** on the left or right side. The rear cooking zone display will show "L7", while the front cooking zone display will show "0". The desired heat setting is selected by sliding your finger across the setting selection sensor field . • • .



In order to deactivate the Bridge function touch and hold sensor of the cooking zone **B** with symbol „L7" for 3 seconds. The respective cooking zone displays will show "0".

Now both cooking zones can be controlled independently.

Check if cookware is suitable for a cooking zone

▶ You can check if your cookware is suitable for a cooking zone to achieve maximum efficiency and use the full power of the cooking zone.

Test procedure:

- Pour a little water into your cookware and place it in the middle of the cooking zone.
- Turn on the hob.
- When cookware is detected, simultaneously touch and hold for 3 seconds the detected cooking zone selector and then  touch sensor until you hear a beep
- The  and  symbols will alternate on the display indicating that test is in progress.
- After the test (max. 20 seconds) the display will show a result ranging from 00 to 99.
- The hob will turn off automatically.



Do not move the cookware during the test.

The result of 99 indicates that cookware is ideal for use on a cooking zone.

The result displayed is indicative only and depends on cookware base diameter, material and how it is built.

You can use cookware when the result is 60 or more. If the cookware base diameter is less than that of the cooking zone and the result is below 60, repeat the test on a smaller available cooking zone. If you use cookware with test result below 60, cooking will take longer and will be less efficient.

Test result of 00 means that cookware is not suitable for use with an induction hob.

CLEANING AND MAINTENANCE

Proper routine maintenance and cleaning of the appliance can significantly extend its trouble-free operation.



When cleaning induction hobs, the same principles apply as for glass surfaces. Do not use under any circumstances any abrasive or caustic cleaners or scouring powders or pads! Do not use steam or pressure cleaners.

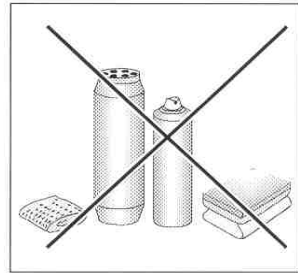

Cleaning after each use

- Wipe light stains with a damp cloth without detergent. The use of dishwashing liquid may cause a bluish surface discoloration. These persistent stains cannot always be removed right away, even using a special cleaner.
- **Firmly adhering dirt can be carefully removed with a scraper. Then wipe the cooking surface with a damp cloth.**

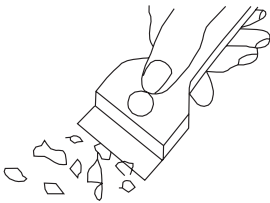

Scraper to clean the hob

Removing stains

- **Bright stains of pearl colour (residual aluminium)** can be removed from the cool hob using a special cleaning agent. Limestone residue (eg. after evaporated water) can be removed by vinegar or a special cleaning agent.
- Do not turn off the cooking zone when removing sugar, food containing sugar, plastic and aluminium foil. Immediately and thoroughly scrape the leftovers off the hot cooking zone using a sharp scraper. Once the bulk of the stain is removed the hob can be turned off and clean the cooled off cooking zone with a special cleaning agent.

Do not use any descaling agents to clean the hob.

Special cleaners are available in supermarkets, electrical and home appliance shops, drug stores, as well as retail food shops and kitchen showrooms. Scrapers can be purchased in DIY and construction equipment stores, as well as in shops carrying painting accessories.

CLEANING AND MAINTENANCE

Never apply a detergent on the hot cooking zone. It is best to let the cleaner dry and then wipe it wet. Any traces of the detergent should be wiped off clean with a damp cloth before re-heating. Otherwise, it can be corrosive.

Warranty will be void if you do not follow the above guidelines!

Periodic inspections

In addition to normal cleaning and maintenance:

- carry out periodic checks of touch controls and other elements. After the warranty expires, have authorised service inspect the appliance every two years,
- repair and identified problems,
- carry out periodic maintenance of the hob.

Important!

If the hob's controls do not respond for whatever reason, then turn off the main circuit breaker or remove the fuse and contact customer GRAM service.

Important!

In the event of breakage or chipping of the hob cooking surface, turn off and unplug the appliance. To do this, disconnect the fuse or unplug the appliance. Then refer the repair to professional GRAM service.

Important!

All repairs and adjustments must be performed by a competent technician or by an authorised installer.

TROUBLESHOOTING

In the event of any fault:

- turn off the appliance
- disconnect the power supply
- have the appliance repaired
- Based on the instructions given in the table below, some minor issues can be corrected by the user. Please check the consecutive points in the table before you refer the repair to GRAM service.

PROBLEM	POSSIBLE CAUSE	REMEDY
1.The appliance does not work	- no power	- check the fuse, replace if blown
2.Sensor fields do not respond when touched	- appliance is not turned on	- turn on the appliance
	- sensor field touched too briefly (less than one second)	- touch the sensor field longer
	- multiple sensors touched at the same time	- always touch only one sensor field (except when a cooking zone is switched off)
3.The appliance does not respond and emits and extended beep	- improper use (wrong sensor fields touched or sensors touched too briefly)	- reconnect the hob
	- sensor fields covered or dirty	- uncover or clean the sensor fields
4.The appliance switches itself off	- no sensor field is touched for 10 seconds of activating the appliance	- switch on the appliance and set heat setting without delay
	- sensor fields covered or dirty	- uncover or clean the sensor fields
5.A single cooking zone switches off and residual heat indicator „H” is shown.	- limited cook time	- switch on the cooking zone again
	- sensor fields covered or dirty	- uncover or clean the sensor fields
	- electronic components overheated	

TROUBLESHOOTING

PROBLEM	POSSIBLE CAUSE	REMEDY
6. Residual heat indicator extinguished even though the cooking zones are hot	- a power outage or the appliance has been disconnected	- residual heat indicator will be shown again the next time the appliance is turned on and off again
7. Hob cooking surface is cracked.	 Danger! Immediately unplug the appliance or switch off the main circuit breaker. Refer the repair to the nearest GRAM service centre.	
8. When the problem is still not remedied.	Immediately unplug the appliance or switch off the main circuit breaker (fuse). Refer the repair to the nearest GRAM service centre. Important! You are responsible for operating the appliance correctly and maintaining its good condition. If you call GRAM service as a result of operating the appliance incorrectly you will be responsible for the costs incurred even under warranty. The manufacturer shall not be held liable for damage caused by failure to follow this manual.	
9. Induction hob makes buzzing sound.	This is normal. Cooling fan is operating to cool down internal electronics.	
10. Induction hob makes hissing and whistling sounds.	This is normal. When using several cooking zones at full power, the hob makes hissing and whistling sounds due to the frequencies used to power the coils.	
11. The hob does not work. The cooking zones will not operate.	- faulty electronics	- reset the appliance, unplug it for a 60 seconds (disconnect the fuse).

SPECIFICATION

Rated voltage	230/400V~ 50Hz
Rated power:	7,35 kW
Model:	KKI 7164-91 TI
- induction cooking zone :	
- induction cooking zone: 2 x Ø 180 mm	1600/2500 W
- induction cooking zone: 1 x Ø 210-220 mm	2000/3000 W
- induction cooking zone: 1 x Ø 160-180 mm	1200/1400 W
Dimensions	59x780x522
Weight	ca.9,8 kg

Meets the requirements of European standards EN 60335-1; EN 60335-2-6.

NO:

Gram A/S

Tel.: 22 07 26 30

www.gram.no

SE:

Gram A/S

Tel.: 040 38 08 40

www.gram.se

FI:

Gram A/S

Tel.: 020 7756 350

www.gram.fi

GRAM

Gram A/S

Gejlhavegård 2B

DK-6000 Kolding

+45 73 20 10 00

www.gram.dk